

HLA-DR genotypes in familial rheumatoid arthritis: increased frequency of protective and neutral alleles in a multicase family.

Szilvia Zsilák, János Gál, László Hodinka, Katalin Rajczy, Attila Balog, Sándor Sipka, Sándor Baráth, Anikó Kapitány, Erika Zilahi and Zoltán Szekanecz

J Rheumatol 2005;32;2299-2302
<http://www.jrheum.org/content/32/12/2299>

1. Sign up for TOCs and other alerts
<http://www.jrheum.org/alerts>
2. Information on Subscriptions
<http://jrheum.com/faq>
3. Information on permissions/orders of reprints
http://jrheum.com/reprints_permissions

The Journal of Rheumatology is a monthly international serial edited by Earl D. Silverman featuring research articles on clinical subjects from scientists working in rheumatology and related fields.

HLA-DR Genotypes in Familial Rheumatoid Arthritis: Increased Frequency of Protective and Neutral Alleles in a Multicase Family

SZILVIA ZSILÁK, JÁNOS GÁL, LÁSZLÓ HODINKA, KATALIN RAJ CZY, ATTILA BALOG, SÁNDOR SIPKA, SÁNDOR BARÁTH, ANIKÓ KAPITÁNY, ERIKA ZILAH I, and ZOLTÁN SZEKANECZ

ABSTRACT. Objective. We describe a unique family where each of the 5 siblings in the second generation has rheumatoid arthritis (RA). Two other members of the family have RA and systemic lupus erythematosus (SLE), respectively. No members of previous generations in the family had documented inflammatory arthritis. Due to the suspected genetic predisposition, HLA-DR genotypes were determined in the affected siblings and their parents, children, and grandchildren. We investigated the possible role of various HLA-DR alleles in the evolution of RA in this multicase family.

Methods. HLA-DRB1* alleles were determined by polymerase chain reaction using the sequence-specific primer–Olerup method.

Results. The most common alleles in the 6 persons with RA were HLA-DRB1*07 and DRB1*15, which are known to be protective and neutral in RA. No patient or family member carried any HLA-DR4 alleles.

Conclusion. HLA-DRB1*07 and DRB1*15 alleles are thought to be protective or neutral in RA. However, the majority of RA patients in the family and nearly half of all family members carried these alleles, suggesting a role of these genotypes in susceptibility to RA. No RA patient in this family carried HLA-DR4 alleles. Thus, in our rare family with 6 RA cases, an unexpected genetic background may be involved in the increased susceptibility to inflammatory arthritis. (J Rheumatol 2005;32:2299–302)

Key Indexing Terms:

RHEUMATOID ARTHRITIS FAMILY TREE HLA-DRB1 ALLELES SHARED EPITOPE

Susceptibility to and severity of rheumatoid arthritis (RA) show a clear association with certain HLA-DR1, DR4, and DR10 haplotypes¹⁻³. In contrast, HLA-DR2 or DR7 genotypes may be rather protective or neutral regarding development of the disease^{2,3}. In this series of cases we describe a unique Hungarian family where autoimmune inflammatory diseases show an extreme familial aggregation. Each of the

5 siblings representing the second generation has RA, while 2 of the third generation have RA and systemic lupus erythematosus (SLE), respectively.

By determining HLA-DR genotypes, we investigated whether alleles known to be involved in higher susceptibility to RA or other genotypes could account for the unexpected aggregation of 6 cases of RA and one of SLE within one family.

From the National Institute of Rheumatology and Physiotherapy, Budapest; Department of Rheumatology, County Hospital, Kecskemét; National Medical Center, Institute of Haematology and Immunology, Budapest; Department of Microbiology and Immunobiology, University of Szeged, Szeged; and Regional Laboratory of Immunology and Division of Rheumatology, Third Department of Medicine, University of Debrecen Medical Center, Debrecen, Hungary.

S. Zsilák, MD, National Institute of Rheumatology and Physiotherapy, Department of Rheumatology, County Hospital, Kecskemét; J. Gál, MD, Department of Rheumatology, County Hospital, Kecskemét; L. Hodinka, MD, PhD, National Institute of Rheumatology and Physiotherapy; K. Rajczy, PhD, National Medical Center, Institute of Haematology and Immunology; A. Balog, MD, Department of Microbiology and Immunobiology, University of Szeged; S. Sipka, MD, DSci; S. Baráth; A. Kapitány; E. Zilahi, PhD, Regional Laboratory of Immunology, University of Debrecen Medical Center; Z. Szekanecz, MD, PhD, Division of Rheumatology, University of Debrecen Medical Center.

Address reprint requests to Dr. S. Zsilák, National Institute of Rheumatology and Physiotherapy, 38-40 Frankel Leó str, Budapest, H-1023, Hungary. E-mail: zsilaksz@freemail.hu

Accepted for publication July 26, 2005.

MATERIALS AND METHODS

The family tree is shown in Figure 1. Ethnically, all members of the family are Caucasians. Each patient with RA fulfilled the 1987 American College of Rheumatology (ACR) classification criteria for RA⁴. In addition, the diagnosis was confirmed by hand magnetic resonance imaging and determination of anti-cyclic citrullinated peptide (anti-CCP) autoantibody in the patient (II/4) who fulfilled the criteria for RA and secondary Sjögren's syndrome (SS), besides the possibility of SLE. Core sets of variables of remission criteria were measured regularly by ACR and European League Against Rheumatism standards^{5,6}. Rheumatoid factor (RF) was assessed by immunoturbidimetry. Antinuclear antibodies (ANA) were measured by the standard agglutination method. Antibodies to extractable nuclear antigens (ENA: including anti-Sm, nRNP, SSA, SSB, ds-DNA, ss-DNA) were determined by counterimmunoelectrophoresis. Anti-CCP antibody was assessed by ELISA. Radiographs of hands and feet were scored by the Larsen scoring system⁷.

Genotyping was carried out in 30 family members altogether. Genomic DNA from whole blood containing EDTA was extracted by standard techniques (High Pure PCR Template Preparation Kit, Roche, Budaors,

I. Generation

II.

III.

IV.

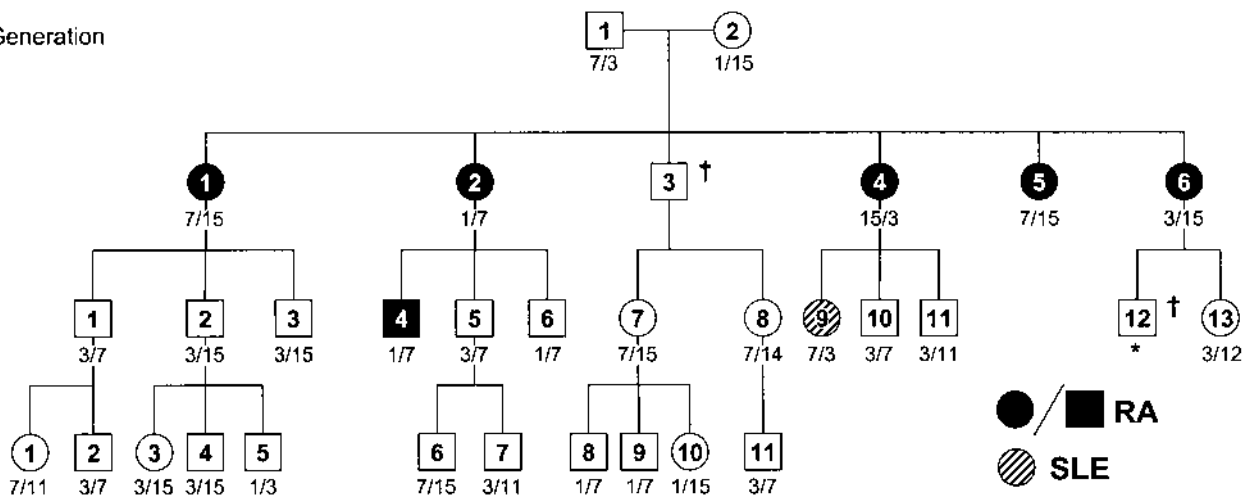

Figure 1. Family tree showing HLA-DR genotypes. *Died at age 3 months due to developmental anomalies. † Deceased.

Hungary). HLA-DRB1 allelic variants were determined using polymerase chain reaction amplification with sequence-specific primers (SSP) based on the procedure of Zetterquist and Olerup (Olerup SSP DR-low resolution kit, GenoVision, Oslo, Norway).

The major clinical laboratory characteristics of the individual cases are shown in Tables 1 and 2.

RESULTS

Results of HLA-DR genotyping are illustrated in Figure 1. None of the family members carried HLA-DRB1*04 alleles. However, HLA-DRB1*01 alleles were found in 8 family members. Only 2 patients with RA (II/2, III/4) carried this genotype.

Four of 6 patients with RA (II/1, II/4, II/5, II/6) carried HLA-DRB1*15. HLA-DRB1*07 alleles were detected in 4/6 RA patients (II/1, II/2, II/5, III/4). Two of 6 RA patients carried HLA-DRB1*03.

The patient with SLE (III/9) carried both the HLA-DRB1*03 and the HLA-DRB1*07 alleles.

DISCUSSION

We describe 30 members of a rather unique family. Five sis-

ters of the second generation, and a male in the third generation have RA. In addition, another family member has SLE. We performed HLA-DR genotyping of all 30 available members of the family in order to assess the possible role of certain HLA-DRB1 alleles in susceptibility to RA.

RA is strongly associated with HLA-DRB1 molecules sharing a common amino acid sequence in their third hyper-variable region called the shared epitope (SE)^{2,3}.

In our multicase family, none of the 30 family members carries HLA-DR4 alleles. The frequency of the HLA-DRB1*01 allele is very low as well (8/30). Only 2/6 patients with RA carried this allele. In our recent study in Hungarian patients with RA, the frequency of HLA-DR4 alleles was found to be significantly increased in the patients with RA (31%) compared to controls (11%). HLA-DR1 alleles were detected in 32.5% of RA patients compared to 18% of controls⁸.

In agreement with other studies, our analysis showed that familial history of RA was not predictive for the progression of radiological damage¹. Erosion was detectable in only one of our patients (II/4).

Table 1. Clinical characteristics of patients with rheumatoid arthritis (RA) and systemic lupus erythematosus (SLE).

	Age at Disease Onset/ Present age, yrs	Sex	Radiographic (Larsen) Score	Present Therapy	DAS28, min/max	Interventions	DR1+	DR4+	HLA-DR Genotype
II/1, RA	25/56	F	8	MTX, SSZ	2.11/7.10	—	Neg	Neg	7/15
II/2, RA	24/54	F	21	MTX, LEF, MP	4.42/6.45	Left knee RSO	Pos	Neg	1/7
II/4, RA, SS*	39/50	F	29	LEF, MP	2.02/8.46	Right, left knee RSO	Neg	Neg	3/15
II/5, RA	21/39	F	1	MTX, SSZ, CQ, MP	2.86/5.67	—	Neg	Neg	7/15
II/6, RA	33/37	F	4	CQ, MP	5.59/6.00	—	Neg	Neg	3/15
III/4, RA	34/36	M	8	MTX, SSZ, MP	2.71/3.76	—	Pos	Neg	1/7
III/9, SLE	23/29	F	—	MP	—	—	Neg	Neg	3/7

CQ: chloroquine, LEF: leflunomide, MP: methylprednisone, MTX: methotrexate, RSO: radiosynoviorthesis, SSZ: sulfasalazine, DAS: Disease Activity Score.

* Secondary Sjögren's syndrome.

Table 2. Potential diagnostic findings of autoimmune inflammatory disorders in 6 patients with RA and one with SLE.

	II/1	II/2	II/4	Patient II/5	II/6	III/4	III/9
Morning stiffness \geq 1h	+	+	+	+	+	+	-
Arthritis of \geq 3 joints area	+	+	+	+	+	+	+
Arthritis of hand joints	+	+	+	+	+	+	+
Symmetric arthritis	+	+	+	+	+	+	+
Rheumatoid nodules	-	-	+	-	-	-	-
Radiographic changes							
Periarticular osteoporosis/erosion	+/-	+/-	+/+	+/-	+/-	+/-	-/-
Serum RF	-	+	-	-	-	-	+
Other autoantibodies	-	ds-DNA	Anti-CCP, ANA, SSA, SSB, ds-DNA, ss-DNA	-	-	-	ANA, SSA, SSB, ds-DNA, ss-DNA
Episodic/persistent arthritis	-/+	-/+	-/+	-/+	-/+	-/+	-/+
Subjective SS/Schirmer test	+/-	-/-	+/+	-/-	-/-	-/-	+/-
Extraarticular manifestations*	-	-	Leukopenia, anemia	-	-	-	Photosensitivity, urticaria, oral ulcers, myalgia, lupus nephritis, pericarditis (pericardiac tamponade), pleuritis, leukopenia, thrombocytopenia, lymphopenia, anemia SLE
Diagnosis	RA	RA	RA, SS	RA	RA	RA	SLE

* Extraarticular manifestations: pulmonary, cardiac, neurological, nephrological, skin, mucosal, serosal, muscular, gastrointestinal, vasculitis, Raynaud's phenomenon. SS: Sjögren's syndrome, RF: rheumatoid factor.

The most interesting finding was that the 2 most frequent alleles among the patients were HLA-DRB1*15 and DRB1*07. In our recent study, no differences were found between single Hungarian patients with RA and controls with regard to HLA-DR7 (20.4% vs 21.8%, respectively) and DR15 (13.2% vs 14.5%) allele frequencies⁸. The HLA-DRB1*15 allele was carried by 4/6 RA patients in this family. The frequency of this allele is rather high when considering the whole family. Matthey, *et al* described an association between HLA-DRB1*15 and secondary SS in patients with RA⁹. Others have noted significantly increased frequency of HLA-DRB1*15 allele among RA patients with renal involvement¹⁰. In our study no patient had renal involvement, and only patient II/4 had RA-associated SS.

The association of HLA-DR3 with primary SS in Caucasians is well established¹¹. Patient II/4, with RA associated with secondary SS, carried both HLA-DR15 and HLA-DR3 alleles. This result is in agreement with previous reports, according to which the higher risk of primary SS development was associated with the HLA-DRB1*15/DRB1*03 heterozygote genotype¹². In contrast, Gottenberg, *et al* found no relationship between HLA and SS, provided patients have no autoantibodies¹³. Formation of an anti-Ro/SSA autoantibody response was positively associated with HLA-DR15, while DR3 is associated with both anti-Ro/SSA and anti-La/SSB synthesis^{12,13}. Our seronegative RA patient with secondary SS was found to be positive for

anti-SSA and anti-SSB together with an HLA genotype predictive of primary SS. This might suggest the possibility of primary SS as a background to our patient's symptoms. However, considering the typical erosive type of her polyarthritis, and that she is anti-CCP-positive, the diagnosis with RA and secondary SS seems to be appropriate. The genotype of our patient II/6 is HLA-DRB1*15/DRB1*03 as well. However, she has no subjective sicca symptoms, positive Schirmer test results, or anti-SSA/SSB autoantibodies. Apart from these findings, a French team has shown that allele HLA-DRB1*15 has a neutral effect on RA³.

The other most frequent allele regarding the RA patients (4/6) and the whole family (18/30) was HLA-DRB1*07. According to the findings of Reviron, *et al*¹⁴ and Sanchez, *et al*¹⁵, the DRB1*07 allele may have a protective effect on RA. Two of our RA patients (II/2, III/4) carried both the predictive HLA-DRB1*01 and the protective DRB1*07 allele, suggesting that the predictive HLA-DR1 genotype may overrule protective alleles. As well, the study of Gibert, *et al* showed that genotypes with SE alleles were not associated with the risk for RA when the second allele was protective³.

In this family most RA patients carried the HLA-DRB1*07 and/or HLA-DRB1*15 alleles, which in respect of RA are considered protective and neutral alleles, respectively. In another study, we found no association between these alleles and sporadic RA⁸. Moreover, as other autoimmune diseases — SLE and secondary SS — also appear in

this family, HLA-DR7 and DR15 may also account for the association of RA with other systemic disorders within one family. Our study of this multicase family confirms that the genetic background of sporadic and familial RA may differ, and that the genetics of familial RA cannot be completely explained by the “shared epitope” hypothesis.

REFERENCES

1. Radstake TRDJ, Barrera P, Albers JMC, Swinkels HL, van de Putte LBA, van Riel PLCM. Familial vs sporadic rheumatoid arthritis (RA). A prospective study in an early RA inception cohort. *Rheumatology Oxford* 2000;39:267-73.
2. Gregersen PK, Silver J, Winchester RJ. The shared epitope hypothesis — an approach to understanding the molecular genetics of susceptibility to rheumatoid arthritis. *Arthritis Rheum* 1987;30:1205-13.
3. Gibert M, Balandraud N, Touinssi M, Mercier P, Roudier J, Reviron D. Functional categorization of HLA-DRB1 alleles in rheumatoid arthritis: The protective effect. *Hum Immunol* 2003;64:930-5.
4. Arnett FC, Edworthy SM, Bloch DA, et al. The American-Rheumatism Association 1987 revised criteria for the classification of rheumatoid arthritis. *Arthritis Rheum* 1988;31:315-24.
5. Felson DT, Anderson JJ, Boers M, et al. The American College of Rheumatology preliminary core set of disease activity measures for rheumatoid arthritis clinical trials. The Committee on Outcome Measures in Rheumatoid Arthritis Clinical Trials. *Arthritis Rheum* 1993;36:729-40.
6. van Gestel AM, Prevoo ML, van 't Hof MA, van Rijswijk MH, van de Putte LB, van Riel PL. Development and validation of the European League Against Rheumatism response criteria for rheumatoid arthritis. Comparison with the preliminary American College of Rheumatology and the World Health Organization/International League Against Rheumatism criteria. *Arthritis Rheum* 1996;39:34-40.
7. Larsen A, Dale K, Eek M. Radiographic evaluation of rheumatoid arthritis and related conditions by standard reference films. *Acta Radiol Diagn* 1977;18:481-90.
8. Kapitany A, Zilahi E, Szántó S, et al. Association of rheumatoid arthritis with HLA-DR1 and HLA-DR4 in Hungarian patients. *Ann NY Acad Sci* 2005;1051:263-70.
9. Matthey DL, Gonzalez-Gay MA, Hajeer AH, et al. Association between HLA-DRB1*15 and secondary Sjogren's syndrome in patients with rheumatoid arthritis. *J Rheumatol* 2000;27:2611-6.
10. Tokunaga NK, Noda R, Kaneoka H, et al. Association between HLA-DRB1*15 and Japanese patients with rheumatoid arthritis complicated by renal involvement. *Nephron* 1999;81:165-71.
11. Foster H, Stephenson A, Walker D, Cavanagh G, Kelly C, Griffiths I. Linkage studies of HLA and primary Sjogren's syndrome in multicase families. *Arthritis Rheum* 1993;36:473-84.
12. Bolstad AI, Wassmuth R, Haga HJ, Jonsson R. HLA markers and clinical characteristics in Caucasians with primary Sjogren's syndrome. *J Rheumatol* 2001;28:1554-62.
13. Gottenberg JE, Busson M, Loiseau P, et al. In primary Sjogren's syndrome, HLA class II is associated exclusively with autoantibody production and spreading of the autoimmune response. *Arthritis Rheum* 2003;48:2240-5.
14. Reviron D, Perdriger A, Toussiro E, et al. Influence of shared epitope-negative HLA-DRB1 alleles on genetic susceptibility to rheumatoid arthritis. *Arthritis Rheum* 2001;44:535-40.
15. Sanchez B, Moreno I, Magarino R, et al. HLA-DRw10 confers the highest susceptibility to rheumatoid arthritis in a Spanish population. *Tissue Antigens* 1990;36:174-6.